



Office of the City Manager

WORKSESSION  
July 18, 2023

To: Honorable Mayor and Members of the City Council  
From: Dee Williams-Ridley, City Manager  
Submitted by: Jordan Klein, Director, Planning and Development  
Subject: Ashby BART Station Transit-Oriented Development (TOD)

SUMMARY

This report provides an update on activities to facilitate transit-oriented development (TOD) at the Ashby BART station area, including:

- The City's Option to Acquire Air Rights to the Western Parking Lot
- Draft Framework for Community Benefits
- Ashby BART Station Infrastructure and Operations and Future Development
- Additional Funding Sources for Affordable Housing and/or Infrastructure.

The purpose of this worksession is to update the City Council on efforts related to the Ashby BART TOD project and to obtain input about the draft framework for community benefits and other aspects of the project.

CURRENT SITUATION AND ITS EFFECTS

For the past several years, the City and BART have been collaborating to facilitate transit-oriented development at the North Berkeley and Ashby BART sites. The City Council and BART Board of Directors executed a Memorandum of Understanding (MOU) in March 2020 and a Memorandum of Agreement (MOA) in June 2022 that outlined key milestones to advance to a solicitation for developer teams. Several of the milestones outlined in these agreements have been completed already, including:

- Reservation of \$53 million of City Affordable Housing Funding for the North Berkeley and Ashby BART Sites in April 2021.
- New zoning and General Plan amendments consistent with Assembly Bill 2923 adopted in June 2022.

- City and BART adoption of Joint Vision and Priorities for Transit-Oriented Development at the Ashby and North Berkeley BART Station (“JVP”) in June 2022.
- Council approval of preferred option for redesign of Adeline Street at Ashby BART that includes new plaza as a permanent location for the Berkeley Flea Market (November 2022).
- Issuance of a Request for Developer Qualifications and Notice of Funding Availability for the North Berkeley BART station area in July 2022 and selection of a developer team in December 2022.

Due to the additional complex issues that must be resolved prior to issuance of solicitation(s) for developer teams for the Ashby BART station area, the efforts to advance TOD at the North Berkeley and Ashby BART stations are on different timelines. These outstanding issues were identified in the June 2022 MOA. The status of efforts to resolve them are described in more detail below.

#### **A. City’s Option to Acquire Air Rights for the Western Parking Lot**

As a result of an agreement between the City and BART in October 1964 (prior to the construction of BART), and subsequent agreements and transactions including those related to construction of the Ed Roberts Campus, the City of Berkeley retains an option to acquire the air rights over the western parking lot for \$55,000. This arrangement requires cooperation between the City and BART in devising the ultimate terms of a transaction to develop this site.

City staff from the City Manager’s Office, Planning and Development, City Attorney’s Office, Health Housing and Community Services, and Public Works have conducted extensive research to inform options under discussion by the City (led by Major Jesse Arreguin) and BART (led by BART Board Director Lateefah Simon). The negotiating teams are exploring options that would protect and advance both the City’s and BART’s respective objectives, while establishing processes and parameters that do not dissuade the most qualified developer teams from participating in future developer solicitations. Staff anticipates returning to Council in the fall to discuss property negotiations and disposition.

#### **B. Draft Framework for Community Benefits**

The June 2022 MOA outlines a set of minimum requirements for the North Berkeley BART station area transit-oriented development, many of which are derived from the JVP and other City and BART Board-adopted requirements (e.g., project labor requirements). Since the JVP establishes both minimum expectations for development as well as aspirational goals, the intent in the MOA is to clearly convey a minimum level of requirements any potential developer team would be required to

meet for the North Berkeley BART site. The MOA also establishes mechanisms by which BART, the City, or both will reinforce these requirements. Requirements for the North Berkeley BART station area include a project with a residential program with a minimum of 1,000 bedrooms in a variety of sizes, minimum affordability requirements, and a connection to the Ohlone Greenway, among other elements.

The draft framework for community benefits and other project requirements for the Ashby BART site being negotiated by the City and BART reflect: the June 2022 MOA, the JVP, the Adeline Corridor Specific Plan, and key input from a parallel effort, “Equitable Black Berkeley”. Equitable Black Berkeley (EBB) is an initiative spearheaded by the Mayor’s Office, in partnership with Healthy Black Families, that is exploring innovative funding proposals and policies for the Ashby BART station and “Adeline Community” area. This effort is part of a grant-funded, community-driven effort to develop options to support equity, opportunity and the well-being of Berkeley’s African American community.<sup>1</sup> The central premise established by EBB for Ashby TOD is that the project must begin to reverse and repair the inter-generational harm that resulted from the development of the Ashby BART station and redlining.

As noted above, the City has a property interest (the option to acquire air rights) in the western parking lot at Ashby BART, which makes the City a necessary partner in determining the use of the site. The City Council and the BART Board of Directors must ultimately approve the community benefits for Ashby BART, as well as any related agreements and real estate transaction documents. Many of the details, including funding sources and enforcement mechanisms, are still being negotiated, and will be affected by the disposition of the City’s air rights option. The City and BART negotiation teams have been discussing elements of the draft community benefits framework. To date, the BART Board of Directors has not had the opportunity to review or discuss this draft community benefits framework.

The draft framework for community benefits for the Ashby BART station area includes the following elements:

1. **Affordable housing:** Minimum of 35% of new housing units to be developed shall be affordable or Below Market Rate (BMR) housing, with a goal of 50%, in accordance with income targets identified in the JVP (or other Affordable Housing Framework adopted by the City Council for the Ashby BART station area). The draft framework for community benefits reflects proposals being explored to finance the anticipated infrastructure/right-of-way improvements and affordable housing at the Ashby BART site. These proposals include the potential of forming an Enhanced Infrastructure District (EIFD). An EIFD encompassing Ashby (or both Ashby and North Berkeley stations) could capture the City’s share

---

<sup>1</sup> <https://healthyblackfam.org/e4bb>

of any property tax increment over a 45-year period. Income restricted lower income housing units would generally be exempt from property tax so only market rate units would contribute to the tax increment.<sup>2</sup> While some community members have advocated for the Ashby TOD project to be 100% affordable, the funding to finance that amount of affordable housing does not currently exist. Even with the City's reservation of its affordable housing funding, the project would need to rely on application to multiple cycles of future state and federal funding which would add significant delay and uncertainty to the TOD project; for those reasons, BART would not likely agree to this as a minimum requirement. Additionally, there is not a consensus among stakeholders that the entirety of the Ashby BART site should be 100% affordable. Some stakeholders have advocated for a mixed-income community (with 100% affordable projects, including at moderate income levels and market rate projects that could have below market rate inclusionary units) in order to better promote economic mobility and to provide a source of funding (e.g. property tax increment) that goes towards affordable housing and infrastructure needs.<sup>3</sup>

2. **Permanent home for the Berkeley Flea Market.** The Ashby TOD project will include a permanent home for the Berkeley Flea Market and other public markets and microenterprise businesses (e.g., with a plaza, market stalls, and/or other relevant amenities). The City of Berkeley will allow some portion of adjacent Adeline Street right-of-way to also be utilized to support the Berkeley Flea Market (and other public programming). The project will include an installation celebrating the history of the Flea Market, office space for the Flea Market administration, and additional amenities to facilitate the Flea Market and other public markets and microenterprise businesses.
3. **Ground floor space for civic uses at below market rate rent.** Consistent with the vision to have the Ashby BART station area be a vibrant neighborhood center that includes affordable space for community non-profits, the draft framework for community benefits includes a requirement that space at below market rate rent be provided to civic and community uses. The location and amount of space is still being negotiated.

---

<sup>2</sup> Senate Bill 628 "Enhanced Infrastructure Financing Districts" (1/2/2015), Assembly Bill 464 "Enhanced Infrastructure Financing Districts: allowable facilities and projects" (6/29/2021), Assembly Bill 336 "Enhanced infrastructure financing districts: public financing authority: members: joint powers authorities" (6/29/2021).

<sup>3</sup> 4/27/21 City Council Item #31: City Affordable Housing Funds: Ashby and North Berkeley BART Station Areas and Future Housing Funding Notices of Funding Availability (NOFA), Attachment 2, p.36 regarding estimate of City subsidy needed to exceed 35% affordable housing:  
<https://berkeleyca.gov/sites/default/files/documents/2021-04-27%20Item%2031%20City%20Affordable%20Housing%20Funds%20%20Ashby%20and%20North%20Berkeley%20BART%20Station%20Areas%20and%20Future%20Housing%20Funding%20Notices%20of%20Funding%20Availabilit....pdf>

4. **A plaza and/or development that is adjacent and connected to Adeline Street at southern portion of the west parking lot.** The JVP and the Adeline Corridor Specific Plan prioritize that future development should connect directly to the greatest extent possible with Adeline Street. The Ashby TOD project shall be directly connected to Adeline Street at the southern end of the western parking lot (which could be possible through construction of a podium), as shown in the preferred right-of-way redesign concept for Adeline Street at Ashby BART selected by the City Council (see section C below for more details). The connection could become part of the future plaza and/or development. The source of funding for this aspect of the future TOD is still under negotiation and includes identifying grant funding.
5. **A reparative community benefits fund for South Berkeley.** Beyond construction of the TOD project itself, the Ashby BART TOD project can play a deeper role in repairing and reversing the intergenerational harm generated by the displacement of homes and businesses as a result of construction of the Ashby BART station. Equitable Black Berkeley has been central in shaping the proposal that a portion of the revenue generated from the future development project must be dedicated to a fund to be used for and by the greater South Berkeley community. A community advisory committee or similar body would direct the expenditure of the funds. The source of funding for this benefit is still subject to negotiation.

There are also other project elements under discussion which would be included in the future solicitation(s) for developer teams where prospective teams would be encouraged to use their creativity and expertise to include in their project proposals, such as:

- An accessible gymnasium on the east parking lot (to the west of Adeline Street and the Ed Roberts Campus), complementary to existing service providers for persons with disabilities;
- Development that interfaces directly with Adeline Street to the greatest extent possible in additional locations other than the southern portion of the west parking lot (in a manner that meets BART's station operations and BART and the City's life safety requirements);
- Additional publicly accessible civic space, green space or other amenities.

The City and BART have also been discussing other aspects of the project and have reached agreement or are nearing agreement on:

- A two-part developer solicitation process. Due in part to the additional complexity to develop the Ashby BART station site, the solicitation process must consist of a two-part process that includes a request for developer

qualifications, followed by a request for proposals from a short-list of respondents.

- Incorporation of the public artwork by Mildred Howard that was recently commissioned by the City of Berkeley (with the specific location subject to consultation with the artist).
- An interpretive display that satisfies Cultural Resources Mitigation Measure CR-1 in the Ashby and North Berkeley BART Stations Transit-Oriented Development (TOD) Zoning Project EIR.<sup>4</sup>

### C. Ashby BART Station Infrastructure and Operations and Future Development

The Adeline Corridor Specific Plan and the JVP identify a goal to create an at-grade connection between Adeline Street and the planned development on the west parking lot. On April 20, 2023 BART held a community meeting to present information about Ashby BART station operation and infrastructure needs and how that impacts the connection of the future TOD to Adeline Street.<sup>5</sup> BART staff presented information about the design process and constraints that led to the current configuration of the new Traction Power Substation (TPSS) planned for the Ashby Station.<sup>6</sup> BART staff presented the maintenance, access, and clearance requirements for any development on top of or adjacent to the substation (Attachment 1).

BART staff also presented conceptual studies for opportunities for TOD to connect directly to Adeline Street, given safety and operational constraints. Based on information available at this time, the opportunities to connect to future development on the west parking lot to connect to Adeline Street appear to be most constrained in the northern two-thirds of the Adeline Street frontage due to the requirements of the TPSS and safety requirements related to station egress. As noted above, the preferred right-of-way redesign concept for Adeline Street at Ashby BART selected by the City Council included the potential for an expanded plaza at the southern end of the western parking lot. It is anticipated that the future solicitation(s) for developer teams will invite teams to propose creative solutions to maximize opportunities to connect to Adeline Street while still maintaining BART's safety and operational requirements for the Ashby station.

---

<sup>4</sup> <https://berkeleyca.gov/sites/default/files/documents/2022-07-06%20MMRP.pdf>

<sup>5</sup> Presentation from BART's 4/20/23 community meeting is available at:  
[https://www.bart.gov/sites/default/files/docs/23\\_0420\\_Ashby\\_Presentation.pdf](https://www.bart.gov/sites/default/files/docs/23_0420_Ashby_Presentation.pdf)

<sup>6</sup> BART runs trains using electrical power provided by Pacific Gas and Electric (PG&E), which in-turn supplies to over one hundred substations throughout the system that convert electricity to the voltage required to propel BART cars. These substations exist in all kinds of communities throughout the BART system. A traction power substation also exists at the North Berkeley BART station at the southeast corner of the intersection of Acton and Virginia Streets.

#### D. Additional Funding Sources for Affordable Housing and/or Infrastructure

The City and BART recognize that to achieve mutual goals for TOD at the Ashby BART station area, additional funding will need to be identified and secured beyond what the development project can provide to support desired levels of affordable housing, the redesign of Adeline Street, support for the Berkeley Flea Market and other community benefits. City and BART staff are seeking grant and other funding opportunities on an on-going basis. At this juncture, City and BART staff have submitted and/or been awarded the following:

- In 2020 BART secured major grants from Caltrans and the Federal Transit Administration to support planning for TOD, providing approximately \$1,700,000 for work specifically targeting Berkeley BART station area TOD projects, including affordable housing finance and economic analysis, station access planning, and community engagement.
- In June 2023, the City was awarded a \$600,000 grant from the Alameda County Transportation Commission to further refine the preferred concept for redesign of Adeline Street at Ashby BART station.
- In May 2023, BART and the City submitted an application to the State of California's 2021 Regional Early Action Planning Grants (REAP) 2.0 for the Affordable Housing Predevelopment Loan Fund and City of Berkeley Community Benefits Fund.<sup>7</sup>
- In June 2023, the City nominated the Ashby and the North Berkeley BART Station Areas for the Metropolitan Transportation Commission/Association of Bay Area Governments' Priority Site Pilot Program (which provides regional predevelopment funding).

Advancing TOD at the Ashby and North Berkeley BART stations is a Strategic Plan Priority, advancing our goals to:

- Create affordable housing and housing support service for our most vulnerable community members.

---

<sup>7</sup> As part of the required application process, the City Council adopted Resolution 70,687-N.S. on January 31, 2023 to authorize the City Manager to execute a grant agreement with the California Housing and Community Development Department should BART and the City be awarded the grant. The application includes \$10 million for BART to create a predevelopment loan fund to help BART partner with local community development organizations who work in Disadvantaged Communities and often lack the working capital to finance predevelopment work themselves. The application also includes \$1 million to the City of Berkeley to set up its first Enhanced Infrastructure Financing District (EIFD) in the Ashby BART station area in order to increase the number of affordable residential homes in the Ashby TOD project and provide a revenue stream to provide investment in the community that surrounds the Ashby BART station.

- Champion and demonstrate social and racial equity.
- Be a global leader in addressing climate change, advancing environmental justice, and protecting the environment.

### BACKGROUND

Spurred by the passage of Assembly Bill 2923, the City and BART have been closely collaborating for the past few years to advance TOD at the Ashby and North Berkeley BART station areas. A first set of key milestones outlined in the March 2020 MOU between BART and the City of Berkeley were completed in June 2022. These milestones included:

- **Reservation of \$53 million of City Affordable Housing Funding for the North Berkeley and Ashby BART Sites.** The City Council approved a reservation of \$53 million in City affordable housing funds to support at least 35% of the housing units proposed at each of the stations being deed-restricted low, very low and/or extremely low-income affordable housing.
- **New zoning and General Plan amendments consistent with Assembly Bill 2923.** Zoning for the Ashby and North Berkeley BART station areas was amended to be consistent with AB 2923. The zoning amendments established a new Residential - BART Mixed Use (R-BMU) zoning district and amended the Zoning Map to apply the new R-BMU zoning district to the Ashby and North Berkeley BART sites. General Plan amendments added a new land use classification (the Ashby/North Berkeley BART Transit-Oriented Development) and the General Plan was updated for the Ashby and North Berkeley BART sites.
- **City and BART Joint Vision and Priorities for Transit-Oriented Development at the Ashby and North Berkeley BART Station (“JVP”).** The JVP was informed by an 18-month community process that included public meetings with a Council-appointed Community Advisory Group and the community at-large. The JVP builds on the framework provided by the City and BART’s adopted plans, policies and regulations, and the additional land use, site planning and financial feasibility studies undertaken as part of this planning process. The JVP is organized around five key topics: Affordable Housing, Public and Civic Space, Land Use, Building Form, and Station Access, and is incorporated into the City and BART Memorandum of Agreement (See Referenced Links: June 2022 MOA, Exhibit C). The JVP was adopted by both the City Council and the BART Board of Directors in June 2022.

- **City and BART Memorandum of Agreement (“MOA”).** The June 2022 MOA clarifies the processes that BART and/or the City will pursue to develop BART-owned property at North Berkeley BART Station and includes a timeline for pending actions related to the Ashby BART site.

Completion of these milestones enabled BART to issue a Request for Qualifications for developer teams and the City to issue a Notice of Funding Availability for the North Berkeley BART Station Area in July 2022. On December 1, 2022, the BART Board of Directors approved the selection of a development team to build housing at the North Berkeley BART station site. The team comprises lead nonprofit developer BRIDGE, nonprofit development partners East Bay Asian Local Development Corporation (EBALDC) and Insight Housing (formerly Berkeley Food and Housing Project), and market-rate developer Avalon Bay Communities. As outlined in the June 2022 MOA, the City initiated a process to develop Objective Design Standards (ODS) for the North Berkeley BART site in November 2022. Staff is anticipating bringing draft ODS to the Council in November/December 2023.

In addition, in November 2022, the City Council completed a milestone in the June 2022 MOA related to the Ashby BART station area.<sup>8</sup> On November 29, 2022, the City Council selected a preferred concept to redesign the Adeline Street right-of-way at Ashby BART (between Ashby Avenue and Martin Luther King Jr. Way) in order to improve safety and access, and to create a new public plaza that would serve as the new permanent home for the Berkeley Flea Market.<sup>9</sup> The Council adopted a resolution to authorize the City Manager to direct staff to proceed with the preliminary engineering and detailed engineering design based on the recommended conceptual design with Two-Lane Adeline option as the conceptual, pending identification of funding. Redesigning Adeline Street at Ashby BART supports future housing development plans for the Ashby BART station by designing future plaza space that could accommodate the needs of the Berkeley Flea Market that currently utilizes the parking lot (west of Adeline Street).

## ENVIRONMENTAL SUSTAINABILITY AND CLIMATE IMPACTS

Creating equitable, transit-oriented mixed-use development that includes affordable housing and housing support services for Berkeley’s most vulnerable community members is a City Strategic Plan goal, which also helps advance the environmental goals of being a global leader in addressing climate change, advancing environmental justice, and protecting the environment.

---

<sup>8</sup> In addition to the June 2022 MOA, a Council Budget Referral (Feb. 2020) and a recommendation from the Adeline Corridor Specific Plan (Dec. 2020) also identified studying potential reconfigurations of Adeline Street to increase safety and opportunities for public space as a priority.

<sup>9</sup> 11/29/22 City Council Meeting, Item 15: Adeline Street at Ashby BART Conceptual Design: <https://berkeleyca.gov/sites/default/files/documents/2022-11-29%20Item%2015%20Adeline%20Street%20at%20Ashby%20BART.pdf>

POSSIBLE FUTURE ACTION

Following further negotiation meetings between the City and BART, it is anticipated that staff will return to Council in Fall 2023 with proposed amendments to the City and BART's June 2022 Memorandum of Agreement (MOA), as well as related agreements and documentation in order to advance solicitation of developer(s) for the Ashby BART station area.

FISCAL IMPACTS OF POSSIBLE FUTURE ACTION

There are a variety of potential fiscal impacts to the City related to Ashby BART TOD, including the allocation of affordable housing funding, capital expenditures related to Adeline Street roadway reconfiguration, and operational costs related to on-street parking management adjacent to the stations. The actions for possible future consideration by the City Council do not result in direct fiscal impacts, since future funding commitments will return to Council for action. Staff will provide more detail about these potential fiscal impacts in advance of possible future actions.

CONTACT PERSON

Alisa Shen, Principal Planner, Planning Department, (510) 981-7409.

Links to Referenced Documents:

1: June 2022 City and BART Memorandum of Agreement for Transit-Oriented Development at the Ashby and North Berkeley BART Station Areas:

<https://berkeleyca.gov/sites/default/files/documents/UpdatedMOA%20North%20Berkeley-Ashby%20TOD%2005.16.23.pdf>

Attachment:

1: Ashby Substation Access and Clearance Requirements, BART Memorandum, March 15, 2023.



## Ashby Substation Access and Clearance Requirements

**Summary:** This document summarizes the design process and constraints that led to the current configuration of the new Traction Power Substation (TPSS) planned for the Ashby Station. BART understands a desire exists to create an at grade-connection between Adeline Street and the planned development on the western surface parking lot, so this document also aims to outline the maintenance, access, and clearance requirements for any development on top of or adjacent to the substation.

**Background:** BART runs trains using electrical power provided by Pacific Gas and Electric (PG&E), which in-turn supplies to over one hundred substations throughout the system that convert electricity to the voltage required to propel BART cars. These substations exist in all kinds of communities throughout the BART system and are not unique to South Berkeley.

Substation improvements are part of a systemwide effort allowing BART to provide more frequent and timely service and to upgrade and replace aging infrastructure. Measure RR was an approved 2016 bond measure that includes funds to rebuild substations. New substations are included in the Core Capacity program which is partially funded by the Federal government. The construction schedule of the substations has been impacted by the pandemic and ensuing price escalation.

**Current Design:** BART street level facilities allows for more efficient maintenance and emergency access to the traction power equipment, and makes replacing the equipment much less complicated and expensive. The at-grade preference is being pursued at Ashby Passenger Station (Alternative #3), but it is worth noting that BART considered three alternatives at the location:

1. Installing the substation within the footprint of the existing underground facility.
2. Building the Alternating Current (AC) and Direct Current (DC) houses in one large facility adjacent to the existing TPSS
3. Separating the AC and DC houses in a narrower facility adjacent to the existing TPSS.

The first alternative was eliminated because the space couldn't accommodate the new equipment needed for a modern power system. The second alternative eliminated the accessible path to the station at the corner of Adeline St. and Ashby Ave.

The third alternative was ultimately selected because it was most cost effective, and most efficient to maintain.

The following sections detail the access needs that were incorporated into the current design and must be merged into any buildings adjacent to or over the planned substation at the Ashby Passenger Station.



## Ashby Substation Access and Clearance Requirements

### Access Requirements

1. Vehicular Access:
  - a. A minimum of 6 unobstructed parking spaces directly adjacent the facility must be provided for BART service trucks and vans.
  - b. Access to the substation must be provided by specified entrance and exit points, as well as turnarounds for cranes and emergency vehicles must be provided. As required by the California Building Code requirement for Emergency Vehicle Access (EVA) lanes.
  - c. These access points will need to be exclusive to BART and first responders, and that they are separated by bollards.
2. Crane Access: Cranes with a rating axis between 80 and 800-tons must be able to access the facility and manipulate these transformers. This requires the following:
  - a. A clear width of 30 feet for a crane, with an additional 5 feet-clear on both sides to accommodate outriggers.
  - b. A clear length of 175-feet to accommodate a 60-foot crane, the equipment trailer, and working clearances around and between vehicles.
  - c. Any cover over the Ashby TPSS must allow a crane to be staged next to the facility to extend a lifting boom and attached hoisting into the substation, lift it above the wall surrounding the facility, and place it onto a flatbed or carrier vehicle. **Figure 1** shows the working range of a crane BART has identified as capable of lifting all substation equipment. Any development over the substation must accommodate the vertical space necessary to support the operating radius of a capable crane.
  - d. The clearance between the Ashby TPSS and any development must also provide adequate space for replacing electrical equipment. Airspace must be provided to accommodate the hoist and swing of equipment capable of lifting a minimum of 60,000 pounds as refer in Figures 1 & 2. Figures 1 & 2 illustrate the dimensions of equipment known to be capable of meeting BART's maintenance needs.
3. Staging Requirements:
  - a. A secure laydown area of at least 43' x 36' must be included adjacent to the substation to store equipment.
  - b. An additional area must be reserved to accommodate three trailers housing a temporary substation. The average trailer measures 38' L x 9' W x 14' H, so 1,200 square feet (trailers situated end-end-end) or 1,350 sq ft (trailers situated side-side-by side) adjacent to the substation will be required in the event the substation fails. All areas would be off-limits to the public, would need to comply with all applicable building code requirements, and must always be accessible by BART maintenance staff and first responders.



# Ashby Substation Access and Clearance Requirements

## Fire and Life Safety Requirements

This document does not preclude those requirements mandated by the California Building Code, California Occupational Safety and Health Administration, National Electrical Code, Title 24, or any other applicable local, state, and Federal building or safety codes.

# working range – MEGALIFT

## 142'-197' MEGALIFT lift

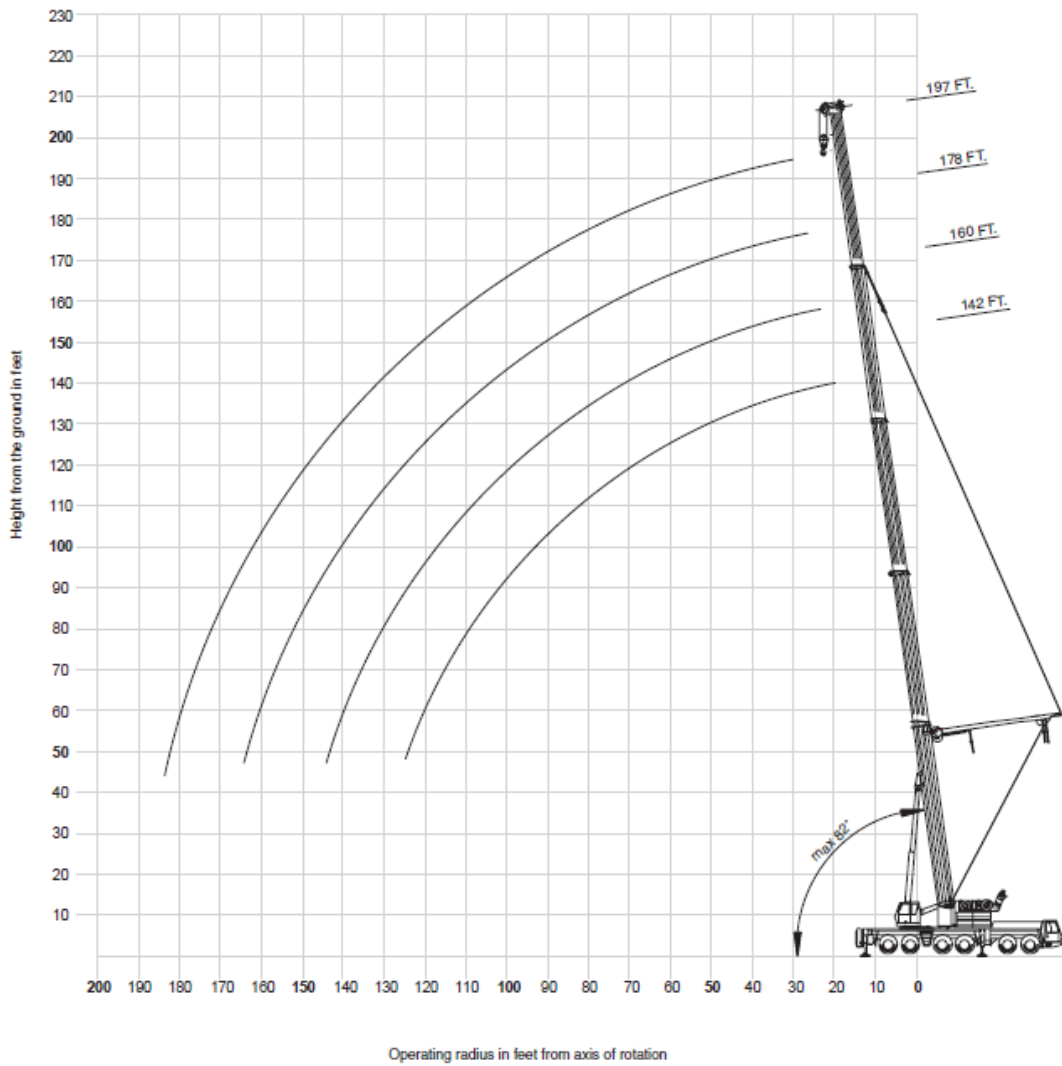

Figure 1: Typical Crane Operating Radius



# Ashby Substation Access and Clearance Requirements

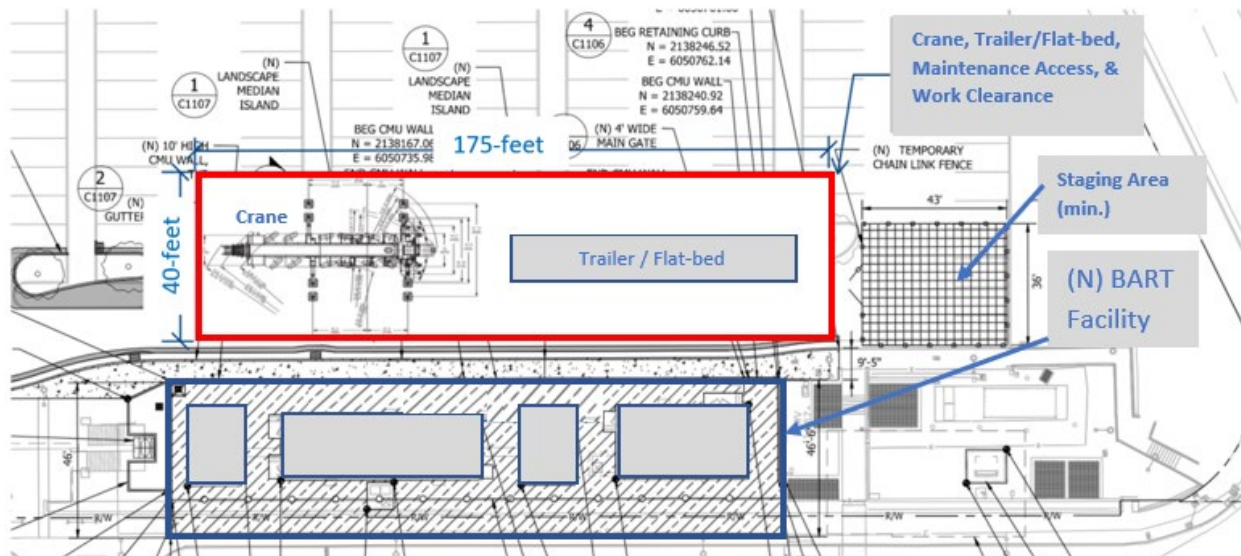

Figure 2: Typical layout of Crane and Trailer at High Voltage (HV) Substation

N.T.S